



sarens

group

www.sarens.com

HYDRAULIC GANTRY



nothing too heavy, nothing too high





HYDRAULIC GANTRY

Specification
Spécifications

Spezifikation
Specificaties

Hydraulic Gantry SWL 250 t

Safe working load SWL

Stage 1

1100 tonnes @ 350 bar

Stage 2

712 tonnes @ 350 bar

Stage 3

400 tonnes @ 350 bar

Control system

Central wireless control console plus local pendant controller to each unit

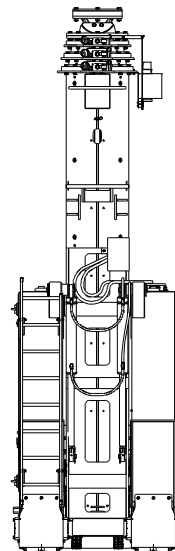
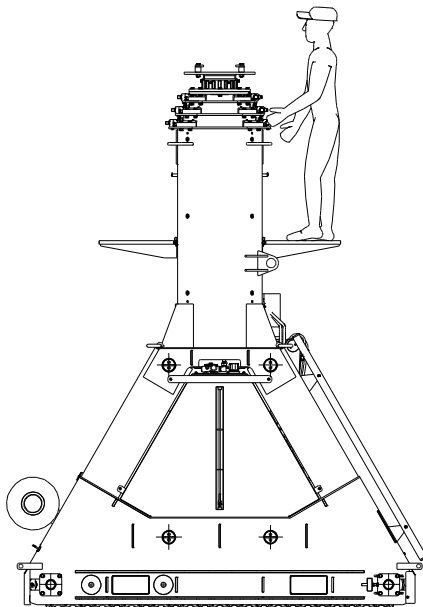
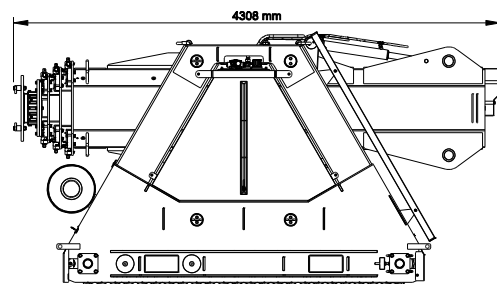
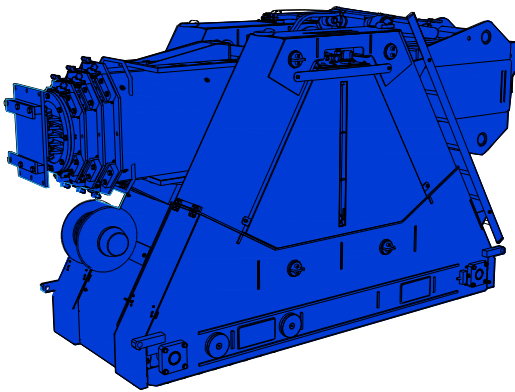

nothing too heavy, nothing too high





HYDRAULIC GANTRY

Specification
Spécifications

Spezifikation
Specificaties

Hydraulic Gantry SWL 100 t

Safe working load SWL

Stage 1	400 tonnes @ 83 bar
Stage 2	400 tonnes @ 120 bar
Stage 3	276 tonnes @ 120 bar

Control system

Central wireless control console plus local pendant controller to each unit

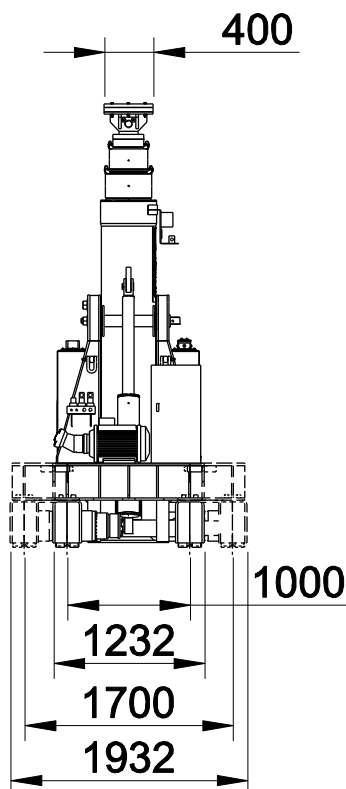
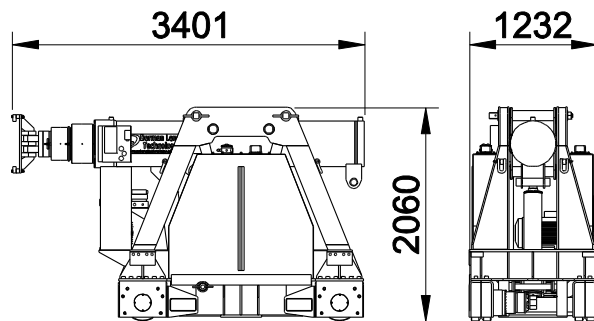
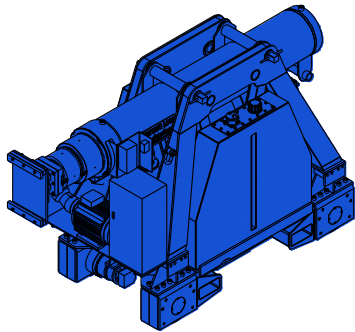

nothing too heavy, nothing too high





HYDRAULIC GANTRY

Specification
Spécifications

Spezifikation
Specificaties

Stage	TG SWL 100 t		TG SWL 250 t	
	Min	Max	Min	Max
0	3555mm	3555mm	4370mm	4370mm
1	3555mm	5555mm	4370mm	7304mm
2	5555mm	7555mm	7304mm	10068mm
3	7555mm	9055mm	10068mm	12002mm

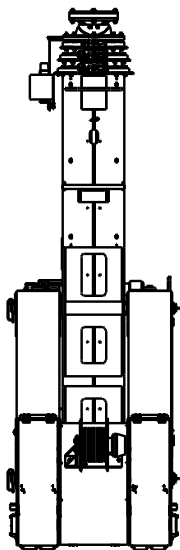

Stage 0

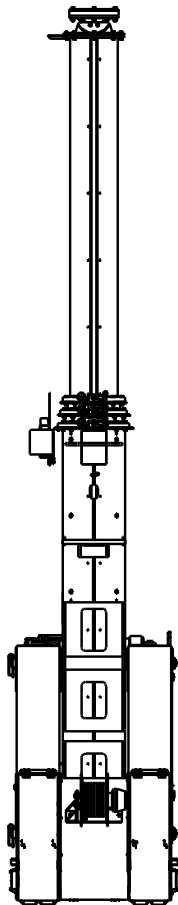

Stage 1

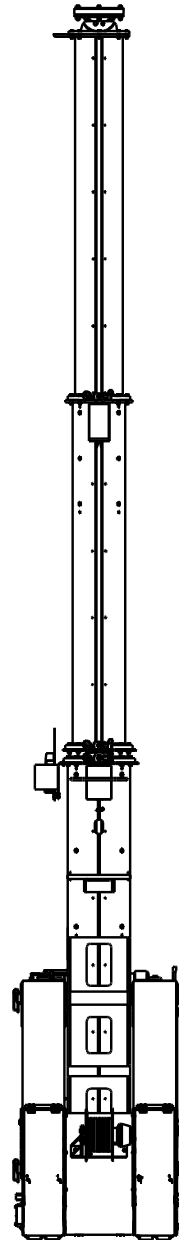

Stage 2

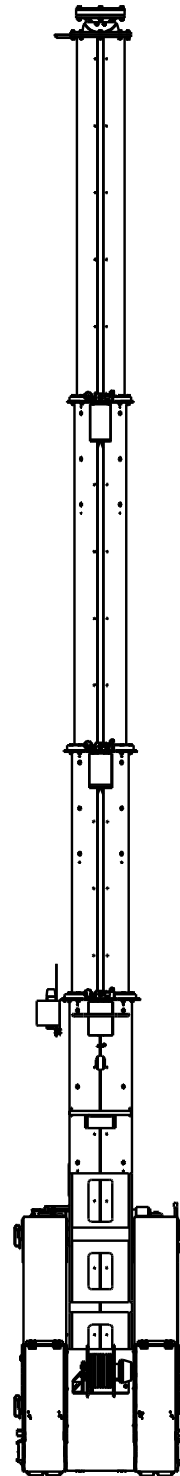

Stage 3

*More info available on request.

V.2012-01-06

nothing too heavy, nothing too high

